

“Blast your sound to the next level”

AVIATOR 115 A

User manual



This manual has been designed to help AVIATOR 115 A system users from Pro DG Systems to its correctly use and understand its benefits and versatility.

Before using the product, carefully read “Precautions” section of this manual (pages 4 - 5). Please keep this document in a safe place for future reference.

In case of flying the system, carefully read “Safety instructions” subsection, located in “Flight hardware” section (pages 33 - 34).

The information included in this document may be changed without prior notice. To stay up to date with the latest version of this document, we recommend that you periodically consult Pro DG Systems website.

When reselling this product, give this document to the new owner. If you supply Pro DG Systems products, please inform your customers about this document.

Index

Precautions	4 - 5
Warranty	5
Declaration of conformity	6
Introduction	
- Description	7 - 8 - 9
- Technical datasheet	9 - 10
- Architectural specifications	10
User guide	
- First steps	11
- Troubleshooting	12 - 13
Components	
- Speaker	14 - 15
- Compression driver	15 - 16
- Horn	17

Amplifier	18
DSP - Software <i>ProDGnet</i>	
- Description	19
- Usage guide in PC	20 to 29
- Selecting presets in the unit itself	30
Flight Hardware	
- Usage in combo format with subwoofer	31
- Rigging points	32
- Safety instructions in case of flying the system	33 - 34
- Flight hardware components	35 - 36
- How to fly the system up	37 - 38 - 39
Ease Focus prediction software	40
Accessories	41

Precautions

Please read, keep and follow all safety and use instructions.

Important Safety Instructions.

1. Heed all warnings.
2. Do not overload the box to avoid damage to the speakers.
3. Do not use this product near water. If the box is used outdoors, make sure that no humidity can enter the box.
4. Clean only with a dry cloth.
5. Do not block any ventilation openings. Install in accordance with the manufacturer's instructions.
6. Do not install near any heat sources such as radiators, heat registers, stoves or similar (including amplifiers).
7. Do not defeat the safety purpose of the polarized or grounding-type plug. A polarized plug has two blades with one wider than the other. A grounding-type plug has two blades and a third grounding prong. The wider blade or third prong is provided for your safety. If the provided plug does not fit in your outlet, consult an electrician for replacement of the obsolete outlet.
8. Protect the power cord from being walked on or pinched, particularly at plugs, convenience receptacles, and the point where it exits from this product.
9. Only use attachments/accessories specified by the manufacturer.
-  10. Use only with the cart, stand, tripod, bracket or table specified by the manufacturer or sold with the product. When a cart is used, use caution when moving the cart/product combination to avoid injury from tip-over.
11. Unplug this product during lightning storms or when unused for long periods of time.
12. Refer all servicing to qualified personnel. Servicing is required when the product has been damaged in any way such as power-supply cord or plug is damaged, liquid has been spilled or objects have fallen into the product, the product has been exposed to rain or moisture, does not operate normally, or has been dropped.

WARNINGS / CAUTIONS:



This symbol on the product means there is uninsulated, dangerous voltage within the product enclosure that may present a risk of electrical shock.



This symbol on the product means there are important operating and maintenance instructions in this guide.



This symbol indicates that the product cannot be treated as ordinary household waste, it must be deposited at the corresponding collection point for electrical and electronic equipment.



This product contains magnetic material. Consult your doctor on whether this might affect your implantable medical device.



Contains small parts which may be a choking hazard. Not suitable for children under age 3.

Warranty

All the Pro DG Systems products have a 24-month warranty period, which begins from the invoice date of the first purchase.

Consult everything relevant to the warranty conditions at Pro DG Systems website: <https://prodgsystems.com/20-vc-warranty.html>

Or via email at: info@prodgsystems.com

Declaration of conformity



Pro DG Systems declares that the product with reference **AVIATOR 115 A** complies with the objectives expressed in the following **European Directives**:

- Low voltage 2014/35/UE.
- Electromagnetic compatibility 2014/30/UE.
- RoHS 2011/65/UE. About restrictions on the use of certain dangerous substances in electrical and electronic equipment.
- RAEE / WEEE 2012/19/UE. About waste electrical and electronic equipment.
- General Product Safety 2023/988/UE.



And it complies with the following **European Harmonized Standards**:

- EN 60065:2014. Audio, video and analog electronic devices.
- EN 55032:2012. Electromagnetic compatibility of multimedia equipment. Part 1: emission requirements.
- EN 55103-2:2009. Electromagnetic compatibility. Part 2 Immunity.

This declaration is available for request by email: info@prodgsystems.com

Or to be downloaded from the website: www.prodgsystems.com

Description

AVIATOR 115 A It is one of the multifunction systems of the new **AVIATOR Series**.

The new AVIATOR Series from **Pro DG Systems** has been developed with the purpose of offering the best quality-price ratio on the market. It has a completely modernized appearance, great power and reduced weight thanks to the incorporation of state-of-the-art Lavoce Italiana components.

Designed in Spain, the new AVIATOR 115 A is the 15" self-powered multifunction system with the best quality-price ratio on the market.

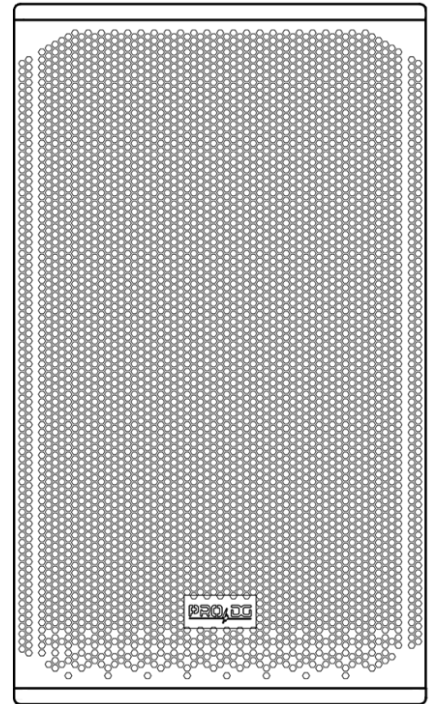

Equipped with one 15" speaker from Lavoce Italiana in a tuned enclosure. The HF section features one 1" compression driver from Lavoce Italiana coupled to a rotatable diffuser, offering a dispersion of 90°x50° (H x V).

AVIATOR 115 A has a **new state-of-the-art Class-D amplification module and its own DSP**, very intuitive to use for easy handling and absolute control. It incorporates one channel with 1000 W RMS @ 8 Ohm for LF and MF + one channel with 300 W RMS @ 8 Ohm for HF.

It incorporates a switching power supply and a limiter system to guarantee the protection of both the amplifier and the other components as well. Includes factory presets.



Remote processing, control and management are carried out through **ProDGnet** software. **ProDGnet** software allows an instantaneous and intuitive view of the status of all systems, as well as absolute control of the different parameters individually (unit by unit).

Ease Focus prediction software is available.

At Pro DG Systems we know the importance for professionals of having a flexible, easily configurable system that guarantees maximum sound performance without the cost of external processors or additional wiring.

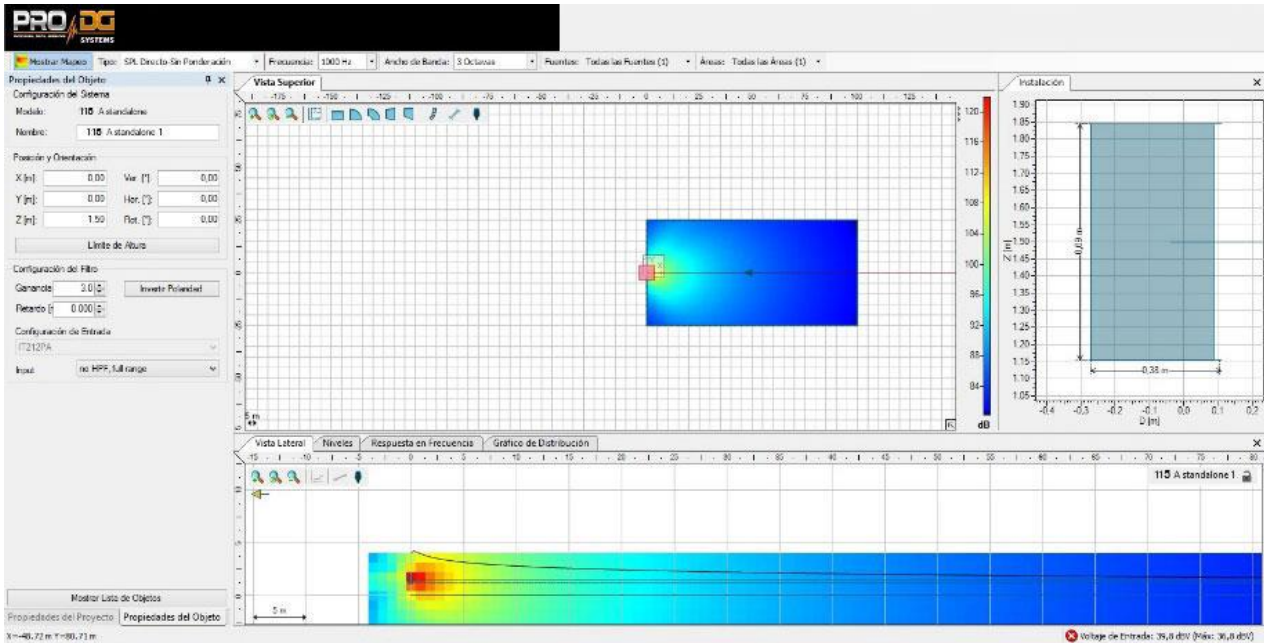

The joint use of *ProDGnet* processing software and Ease Focus prediction software allows you to achieve this objective in seconds, achieving:

- Remote SPL level control.
- Frequency response uniformity for the entire public.
- Digital direction of sound projection in listening areas.
- Reduction of the sound pressure level in areas that should be avoided, such as the stage, walls, or unused balconies.
- Simplification and streamlining of assembly times.

The construction of AVIATOR 115 A system is made of birch plywood using CNC machining, with a special polyurea finish resistant to impacts and inclement weather. Its front part is protected by a robust metal grille and acoustic foam. Includes rigging points for bolt installation.

AVIATOR 115 A features a stand socket to attach an extendable bar, allowing it to work together with a subwoofer unit in combo format. It has 12 rigging points for wall or ceiling installation. It has **hardware and a fly bar** to connect up to three AVIATOR 115 A units in cluster format, for quick and intuitive use.

Easy to transport thanks to its compact, lightweight and ergonomic design, also offering a pleasant visual impact. It incorporates side handles for easy handling.

The perfect solution as main PA, frontfill and sidefill at outdoor events or permanent installation. Ideal for working in live concerts, theaters, coverage under amphitheaters, places of worship, corporate applications and all types of events where high performance and versatility are necessary.

Technical datasheet

AVIATOR 115 A	
Power handling	850 W RMS / 1700 W program / 3400 W peak.
Maximum SPL Calculation	1m / 131 dB continuous / 134 dB program / 137 dB peak.
Nominal impedance	8 Ohm.
Frequency range	45 - 18000 Hz.
Dispersion angle	90°x50° (HxV). Rotatable diffuser.
MF and LF component	One Lavoce Italiana 15" speaker. Ferrite. 800 W RMS.
HF component	One Lavoce Italiana 1" compression driver. Ferrite. 50 W RMS.
Frequency cut-off for MF *	45 Hz Linkwitz-riley 24 filter - 1200 Hz Linkwitz-riley 24 filter.
Frequency cut-off for HF *	1200 Hz Linkwitz-riley 24 filter - 18 kHz Linkwitz-riley 24 filter.
Frequency cut-off for subwoofer *	Up to 90 Hz. Linkwitz-riley 24 filter.
Amplifier	<p>State-of-the-art Class-D. 1 x 1000 W RMS for LF and MF+ 1 x 300 W RMS for HF.</p> <p>Surge protection up to 265 V AC, output protection against overload, clip, limiter.</p> <p>Input type: balanced.</p> <p>Input impedance: 20000 ohms.</p> <p>Input sensitivity: 3 V (+12 dBu).</p>
DSP	24 Bit / 96 KHz. 5 factory presets with selection button.
Pro DG net	1 RS485 input + 1 output link RS485 for network control of the entire system.
Connectors	1 x XLR female (input signal), 1x XLR male (output link). PowerCON NAC3FCB (current supply).

Controls	On / off switch and master volume. Preset selector cursor.
Power supply	AC 90~265V - 50 / 60HZ.
Construction	Birch plywood using CNC machining. 2mm thick perforated steel front grille, with oven-dried black electrostatic powder paint finish. Includes acoustic foam. Includes stand socket to attach extendable bar.
Rigging points	12 x M10
Paint	Special polyurea finish resistant to impacts and inclement weather. Black color (standard).
Dimensions (height x width x depth)	750 x 450 x 440mm (29,53 x 17,72 x 17,32in).
Weight	34 Kg (74,96 lbs) net / 37 Kg (81,57 lbs) with packaging.

* Disrespect the suggested frequency cuts-off on the different ways may cause components breakage.

Architectural specifications

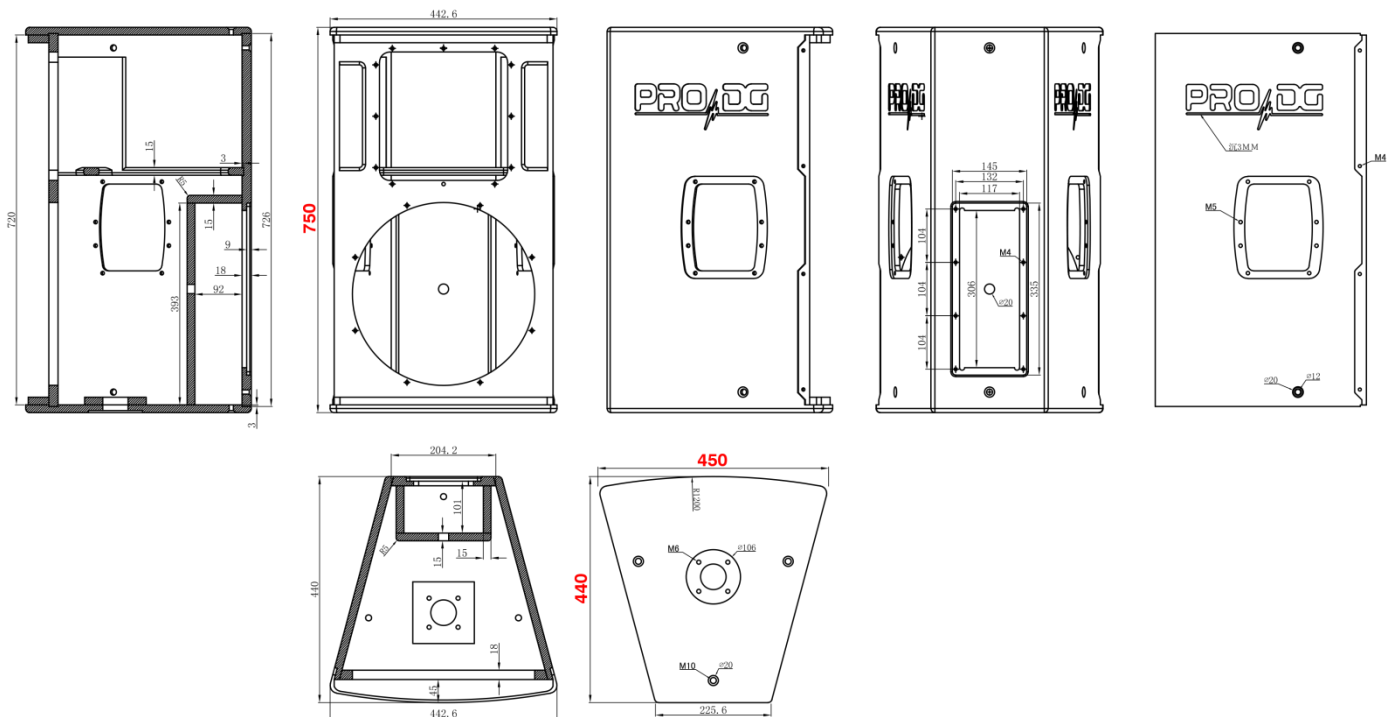

All measures expressed in millimeters (mm).

User guide. First steps

Turning On / Off

Turning on any sound system must be done from back to front. Turn on sources such as CD players first, then the mixer, then the processors, and finally the self-powered loudspeakers. If you have several self-powered loudspeakers, it is advisable to turn them on sequentially one by one.

When turning off the sound system, follow the reverse process, turning off the self-powered loudspeakers before any other element of the system.

Disconnect the device using the mains plug. Both the power connector and the plug must always be accessible and must never be covered or blocked.

To disconnect the power, remove the Powercom type cable from the power connector located on the equipment amplifier, perform this operation on all loudspeakers.

Important: do not unplug the computer when music is playing..

Limiter

AVIATOR 115 A amplifier has a limiter system to protect the equipment.

An excessive level makes the equipment sound bad, causing hearing fatigue, with consequent damage to your health.

Equalization

This system does not need additional equalizers. In any case, values higher than +3dB are not recommended.

Remote control and processing are carried out through the **ProDGnet** software (see page 19 for more information).

Overheating

The amplifier has a cooling system by incorporating an aluminum heatsink plate and forced ventilation. In case of overheating the amplifier will mute to protect itself. In most cases it will be enough to let the unit cool down for it to work properly again.

You must ensure that the ventilation grilles are free of dust and dirt, as well as preventing their obstruction.

User guide. Troubleshooting

Problem	Cause	Solution
The unit does not sound.	<ol style="list-style-type: none"> 1. The signal source is not sending a signal over the cable. 2. Defective cable. 	<ol style="list-style-type: none"> 1. Check the mixer output indicator to see if the signal is being sent. 2. Make sure the cables are connected correctly. If so; use another cable.
The unit does not sound at its maximum level.	<ol style="list-style-type: none"> 1. The mixer or signal source has insufficient output. 2. Possible overheating of the unit. 	<ol style="list-style-type: none"> 1. If you use a mixer, be sure to use balanced output if it has one. Use a mixer or signal source with a higher output level. 2. Lower the master level of the table.
Distorted sound signal.	The mixer or other signal is distorting.	Lower the overall mixer output level or channel gain. Check that the signal source is ok.
Distorted and very loud sound signal.	The system is being overloaded with too much input signal and has reached maximum power.	Lower the mixer output level.
Noise when the unit is connected to a mixer.	<ol style="list-style-type: none"> 1. Probably the output has unbalanced output. Poorly constructed unbalanced to balanced cables are being used. 2. The connections to the electrical network are not correct. 3. The signal cable is too long or too close to the AC line. 	<ol style="list-style-type: none"> 1. Check output and replace wiring. 2. Plug the mixer and powered box into the same outlet. 3. Use a signal cable as short as possible and avoid it being too close to the AC power cable.

<p>Noise or buzz when light controls are used in the same environment.</p>	<ol style="list-style-type: none"> 1. The sound system is connected to the same phase than the lights. 2. The sound cables are too close to the light cables. 	<ol style="list-style-type: none"> 1. Connect the sound system and lighting system to different phases. Request the help of an electrician. 2. Aleje los cables de audio de los cables de luces.
<p>The system does not turn on even though the power cable is correctly connected, both to the network and to the box.</p>	<ol style="list-style-type: none"> 1. Defective cable. 2. Internal fuse blown. 	<ol style="list-style-type: none"> 1. Check the cables, connectors and power outlet with a tester or multimeter. 3. Contact your Pro DG Systems distributor or authorized professional to perform the repair.



If you have any technical problem or questions about Pro DG Systems products; contact our technical support department at: sat@prodgsystems.com

Speaker

AVIATOR 115 A includes one 15" Lavoce Italiana speaker with ferrite magnet, in charge of reproducing low and medium frequencies.



Main characteristics
Power handling of 800 W RMS / 1600 W program
Optimized cooling system
4" edgewound CCA voice coil
Aluminum demodulating ring
Triple roll surround

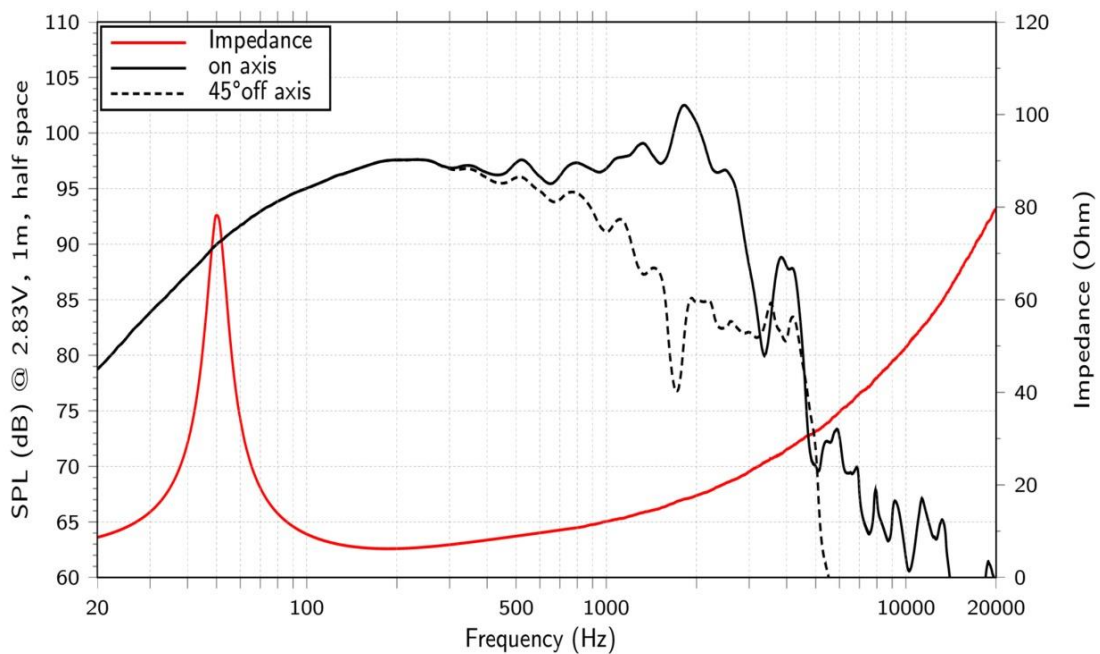

Architectural

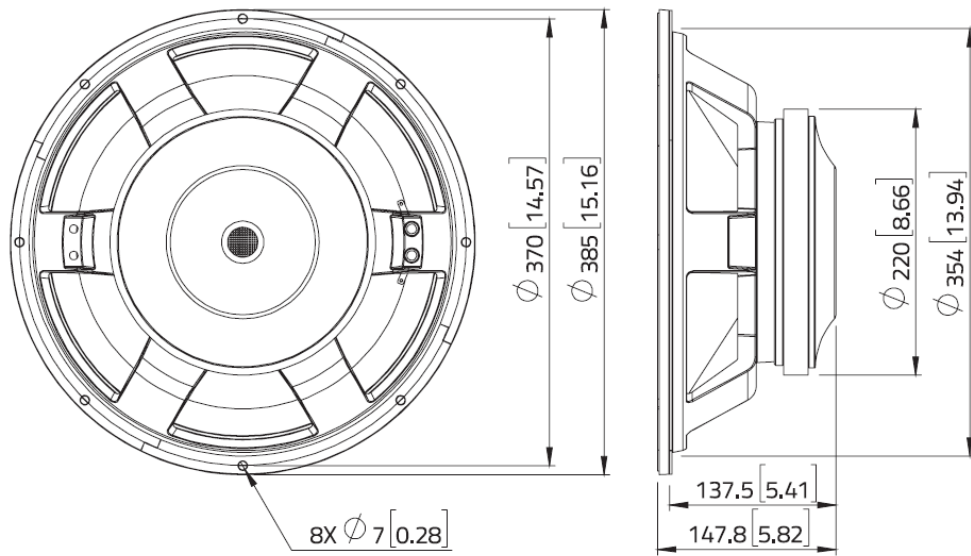

Compression driver

The HF section of the AVIATOR 115 A has one 1" Lavoce Italiana compression driver with ferrite magnet, in charge of reproducing high frequencies.



Main characteristics
Power handling of 50 W RMS / 100 W program
FEM optimized motor, phaseplug and diaphragm
Bobina CCA de 1,7"
High temperature polymeric diaphragm
State-of-the-art HF design
Voice coil copper demodulation ring
1,6 Kg weight

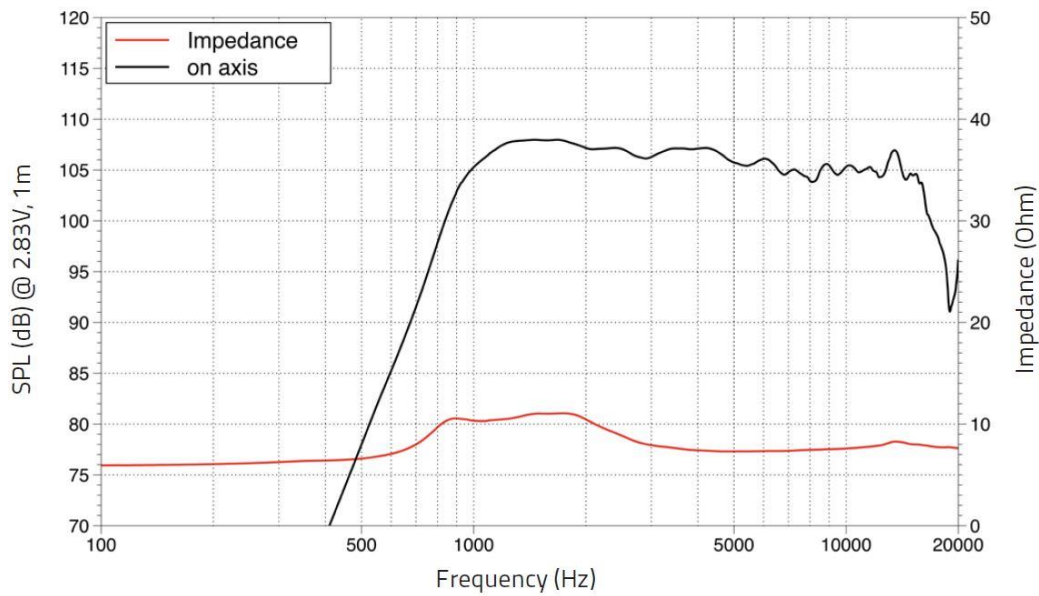

Architectural

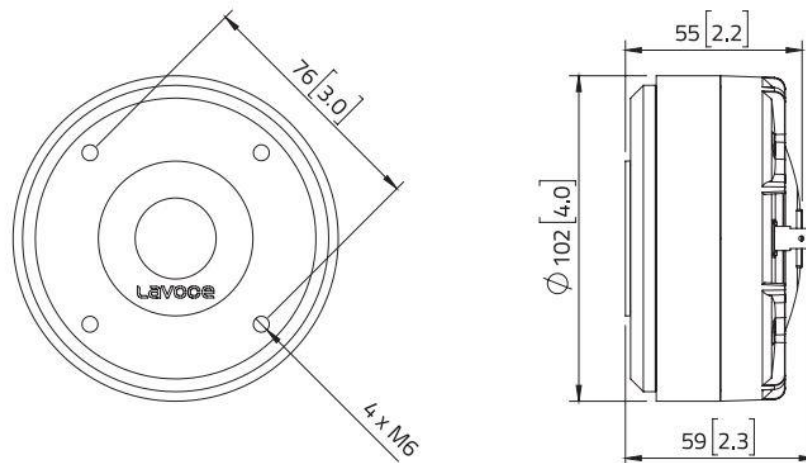

Horn

The compression driver of the AVIATOR 115 A is coupled to a rotatable diffuser (horn) to offer a dispersion of $90^{\circ} \times 50^{\circ}$ (H x V), specifically designed to achieve maximum performance and acoustic quality in high frequencies.

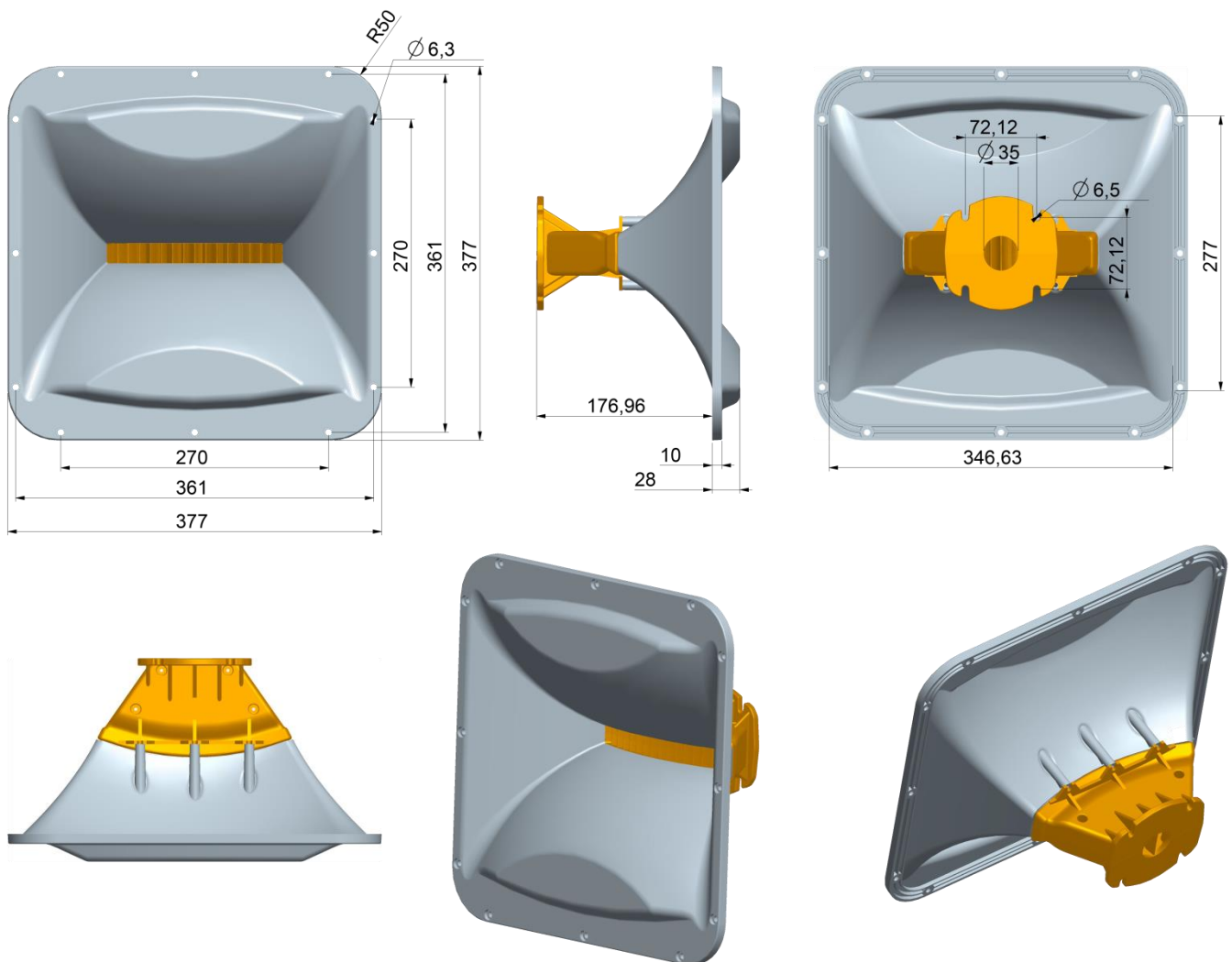

Made of ABS material to offer a low weight. Specially designed to achieve a perfect blend between medium and high frequencies.

Amplifier

AVIATOR 115 A has a **new state-of-the-art Class-D amplifier module and own DSP**, very intuitive to use for easy handling and absolute control.

Incorporates one channel with 1000 W RMS for LF and MF + one channel with 300 W RMS for HF.

Input type: balanced.

Input impedance: 20000 ohms.

Input sensitivity: 3 V (+12 dBu).

Switching power supply with overvoltage protection up to 265 V AC, output protection against overload and limiter system to guarantee protection of the amplifier as well as other components. Includes factory presets.

1. On / Off switch.
2. Powercom connector for current output (link).
3. Powercom connector for current input.
4. Output 1 Signal Limiter Led / Clip.
5. Output 2 Signal Limiter Led / Clip.
6. Presets selector.
7. Signal input connector.
8. Signal output connector (link).
9. Potentiometer for audio output level regulation.
10. Ethernet network input connector (ProDGnet)
11. Ethernet network output connector (ProDGnet).

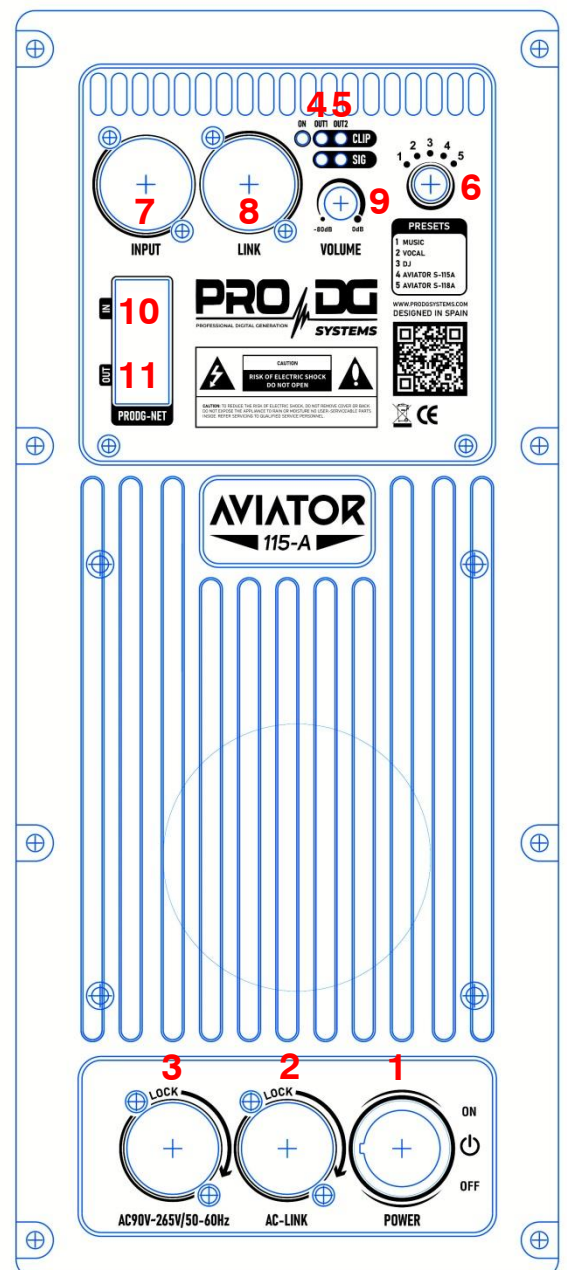

DSP. ProDGnet

Remote processing, control and management are carried out through **ProDGnet** software.



ProDGnet software allows an instantaneous and intuitive view of the status of all systems, as well as absolute control of the different parameters individually (unit by unit).

To operate with **ProDGnet** software from your PC you will only need:

- Download ProDGnet software at Pro DG Systems website (section “Support” > “Software”): <https://prodgsystems.com/19-scrpt-software.html>

Easy to download, all the necessary drivers for installation are included.

Important: the software is currently available for any version of Windows (32 and 64 bits).

- Acquire **ProDGnet** interface (optional), to connect the DSP module housed in the amplifier with your PC. To purchase **ProDGnet** interface contact us at: info@prodgsystems.com or consult your authorized Pro DG Systems distributor.

ProDGnet interface

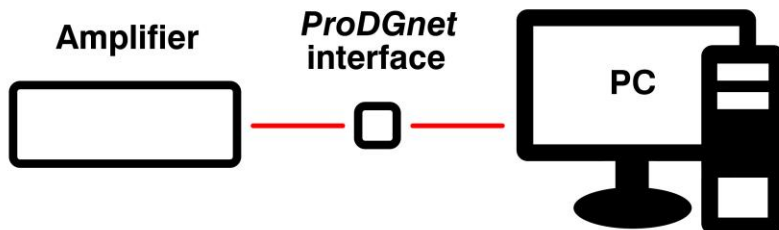

Below is a **guide for use** and information on the different menus of the *ProDGnet software*, which we can see **when we connect the DSP module of the unit to the PC**, through the ProDGnet interface:

Once the software is downloaded on your PC; create your network of Pro DG Systems systems, to do this connect the Ethernet cabling to the different units;

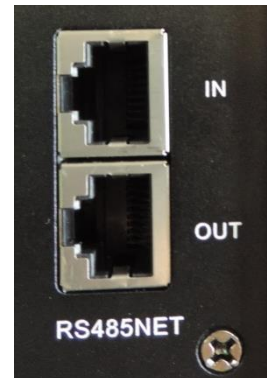

When you start the software, the **general menu** will be displayed by default. (OVERVIEW);

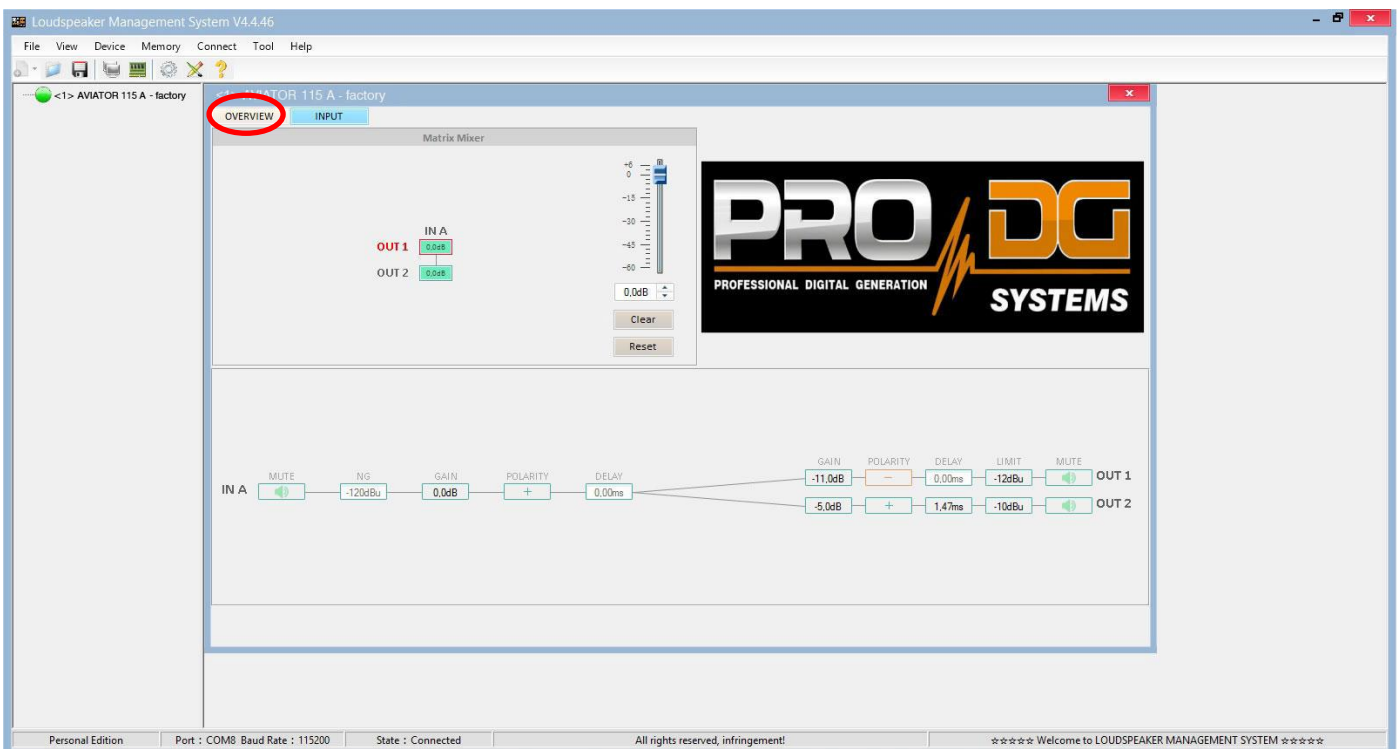

This menu allows modifying different options on input A and outputs 1 and 2, such as: Mute, Limiter, Gain, Polarity and Delay.

When clicking “**Connect**” > “**Remote mode**”, in the top bar;

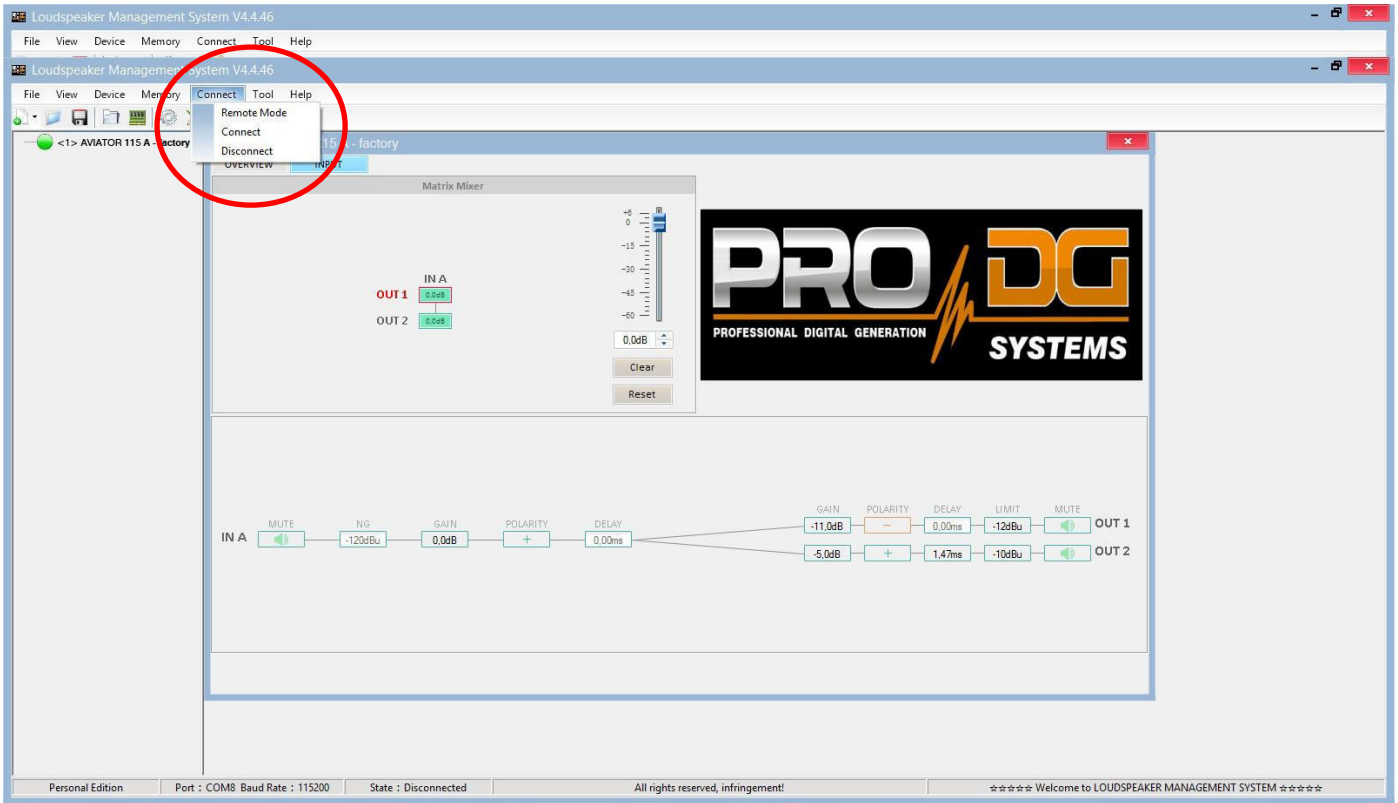

The following dialog box will appear;

Allowing connection to the DSP module of each unit connected to the Ethernet network.

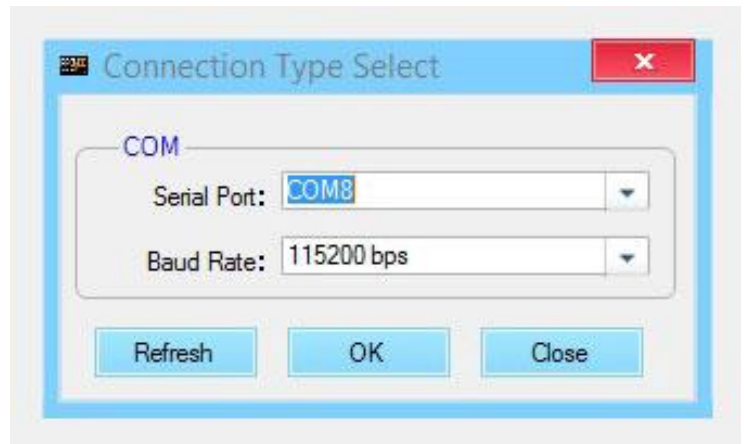

After pressing “OK” all connected units will be displayed (in green) to the left of the menu;

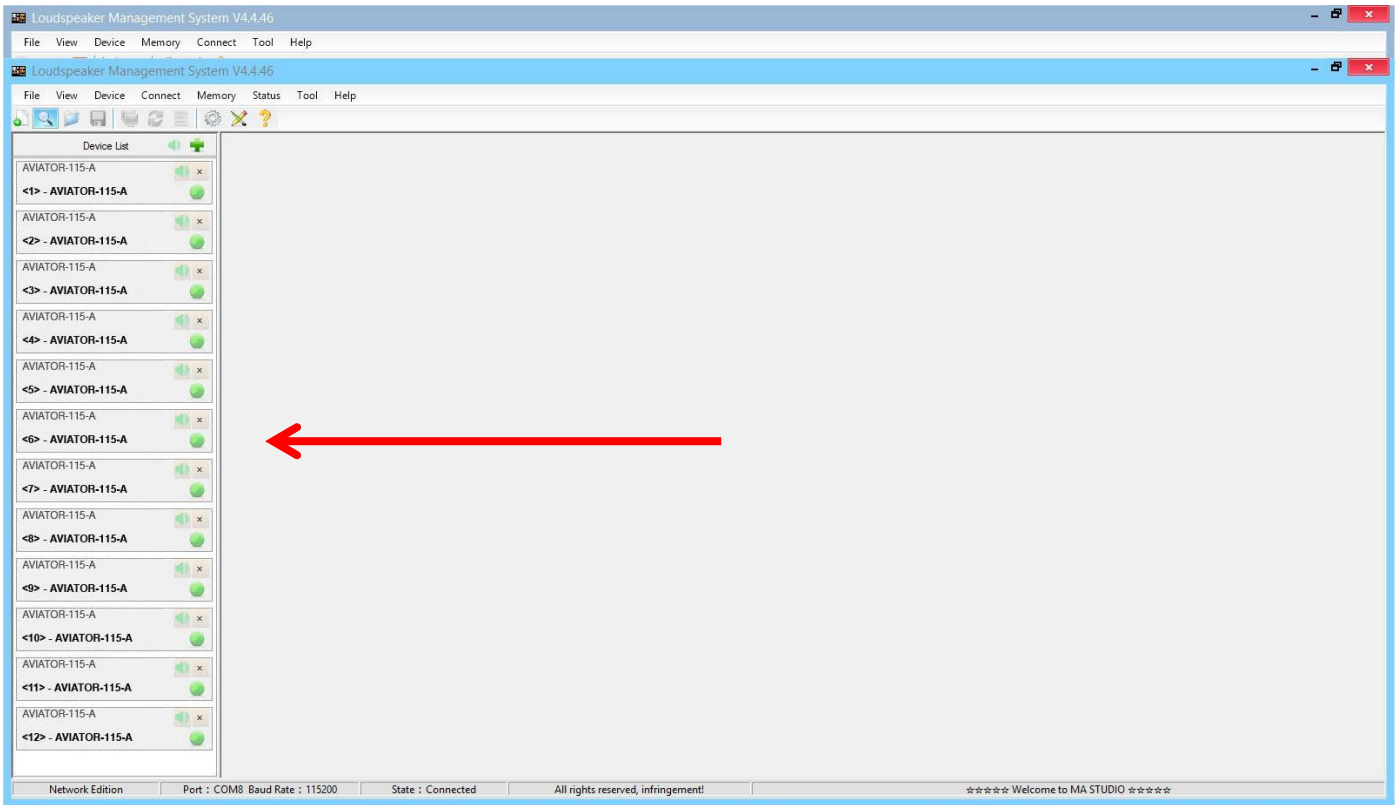

By clicking on the **INPUT** menu, a 31-band parametric equalizer is displayed, allowing you to select the type of Filter, Frequency, Bandwidth (Q), Gain and Bypass;

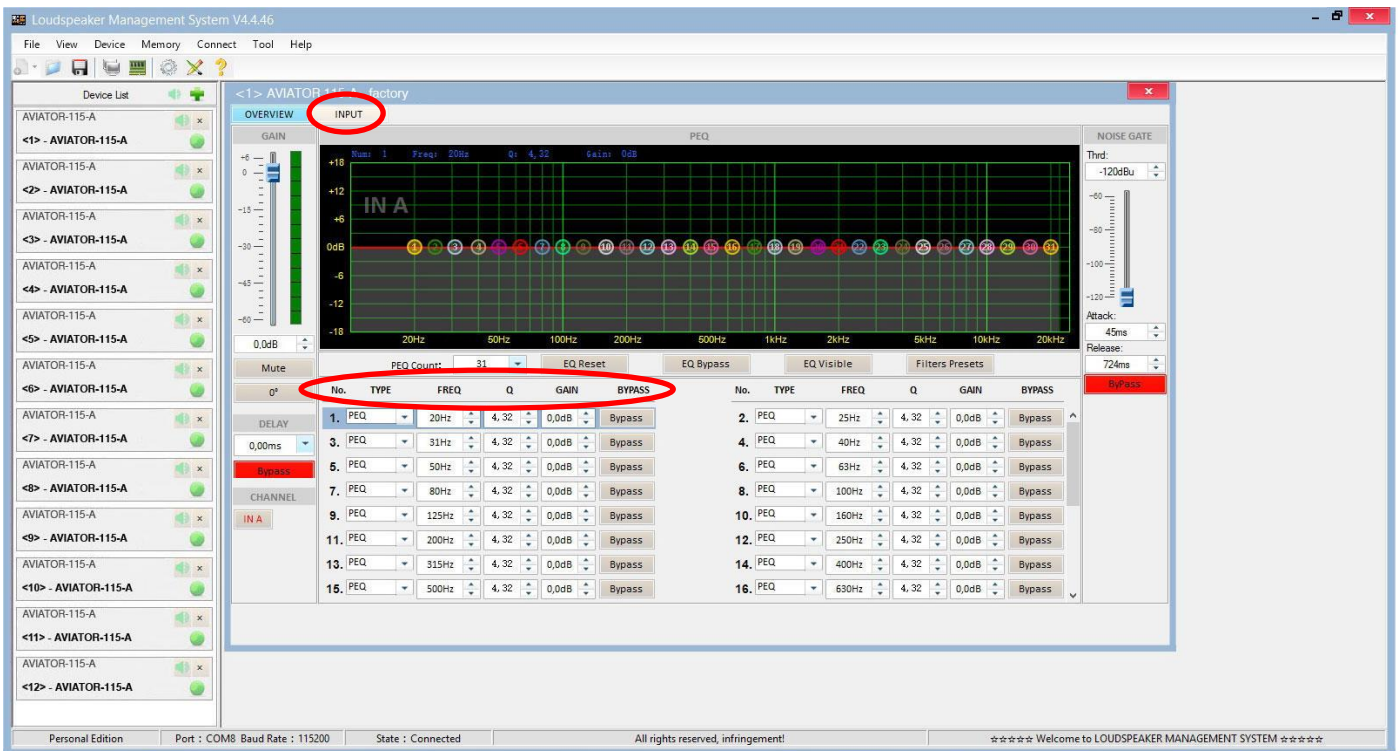

On the left of the menu, you can manually modify Gain, Mute, Delay, Bypass and input channel selection.

To the right of the menu is a noise gate where we find Threshold, Attack, Release and a Bypass of the input noise gate.

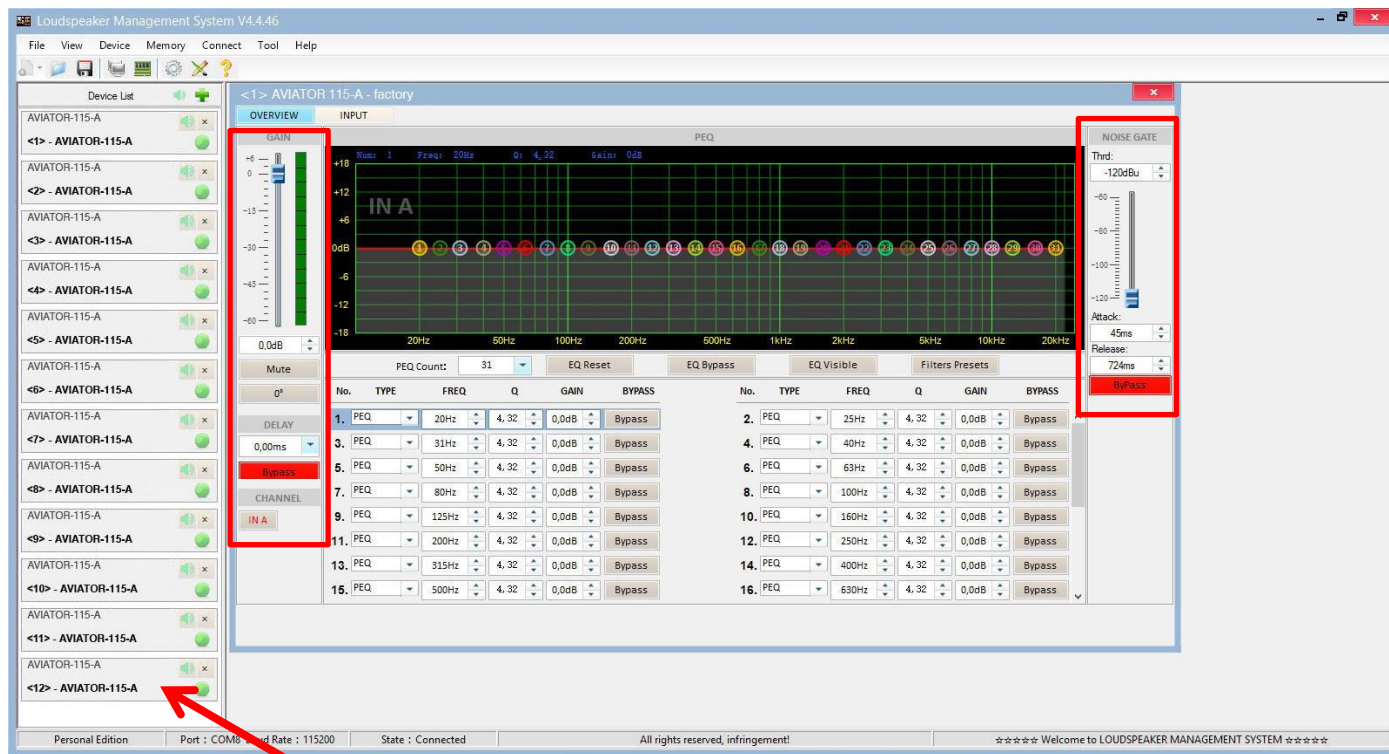

To apply changes to any of the units connected to the ProDGnet network, simply click on the desired unit.

To select factory stored presets, it will be necessary to click “Memory” > “Preset manager”.

The unit has 5 factory presets.

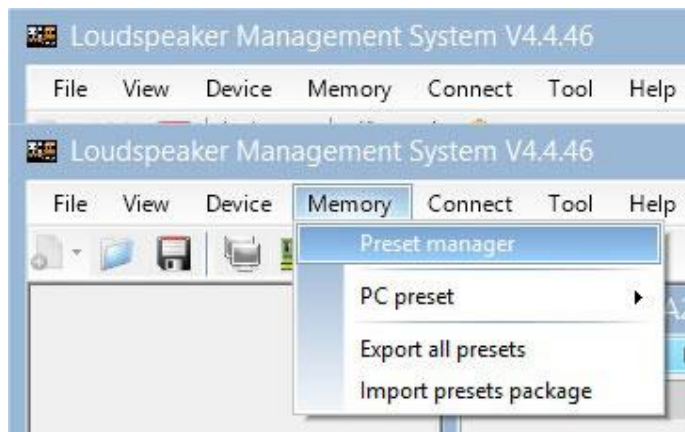

Then, the factory stored preset selection menu will be displayed;

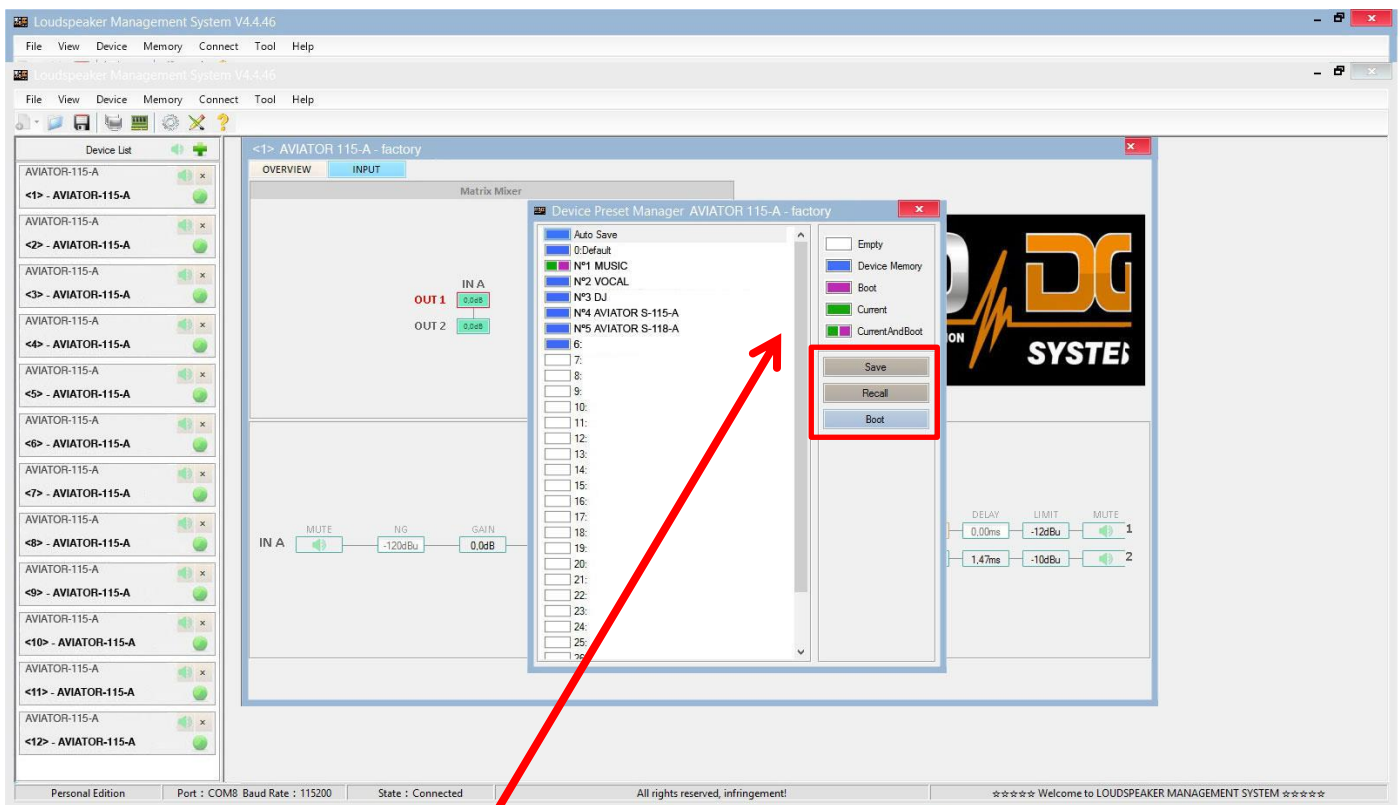

The meaning of the colors shown next to each preset is as follows:

- Empty Preset.
- Preset stored in memory.
- Preset that we want to appear by default when turning on the unit.
- Currently selected preset.
- Preset currently selected and that will appear by default when turning on the unit.

“**Save**” allows saving changes made to the selected preset.

“**Recall**” allows reloading a stored preset.

“**Boot**” allows setting the selected preset as the desired preset that will appear by default when turning on the unit.

To Import or Export presets individually (preset by preset), from PC to amplifier unit or vice versa, it will necessary to click “Memory” > “PC preset”.

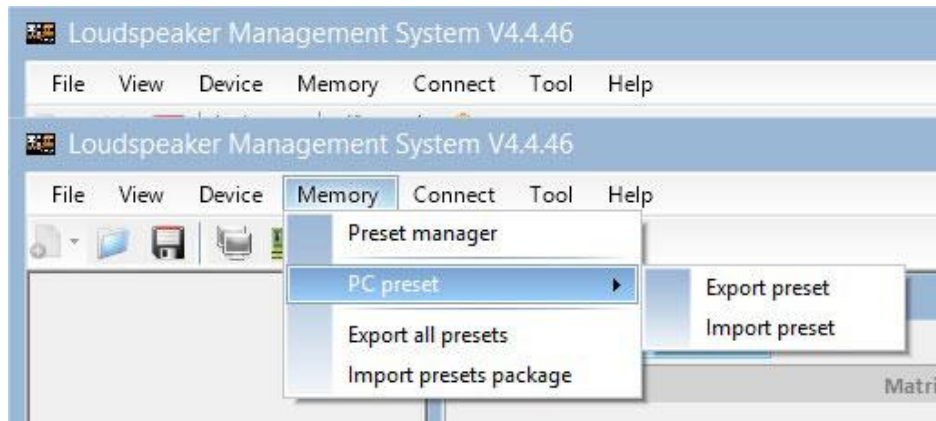

The “Export all presets” tab allows **exporting all the presets stored on the PC to the unit.**

The “Import presets package” tab allows **importing all the presets stored on the unit to the PC.**

To change the language, click “Tool” > “Language”.

If you want to **change the menu color**, click “Tools” > “System Color”.

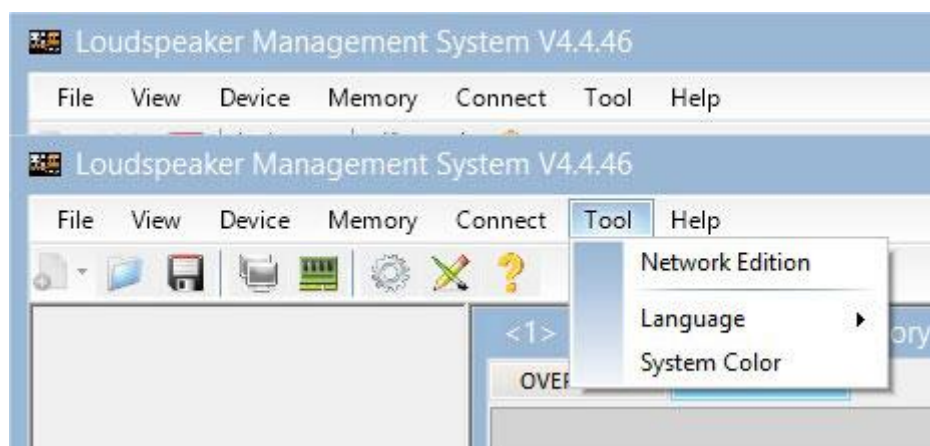

By having a network of systems connected to each other through Ethernet cabling and RS485 protocol, you have the possibility of **creating a group of systems**, which allows any change or equalization made to be applied to all the units that are part of the same network.

For example, if we have twelve units AVIATOR 115 A, when creating a group made up of these units, any change or equalization made will be applied to all units;

Device List	
AVIATOR-115-A	
<1> - AVIATOR-115-A	
AVIATOR-115-A	
<2> - AVIATOR-115-A	
AVIATOR-115-A	
<3> - AVIATOR-115-A	
AVIATOR-115-A	
<4> - AVIATOR-115-A	
AVIATOR-115-A	
<5> - AVIATOR-115-A	
AVIATOR-115-A	
<6> - AVIATOR-115-A	
AVIATOR-115-A	
<7> - AVIATOR-115-A	
AVIATOR-115-A	
<8> - AVIATOR-115-A	
AVIATOR-115-A	
<9> - AVIATOR-115-A	
AVIATOR-115-A	
<10> - AVIATOR-115-A	
AVIATOR-115-A	
<11> - AVIATOR-115-A	
AVIATOR-115-A	
<12> - AVIATOR-115-A	

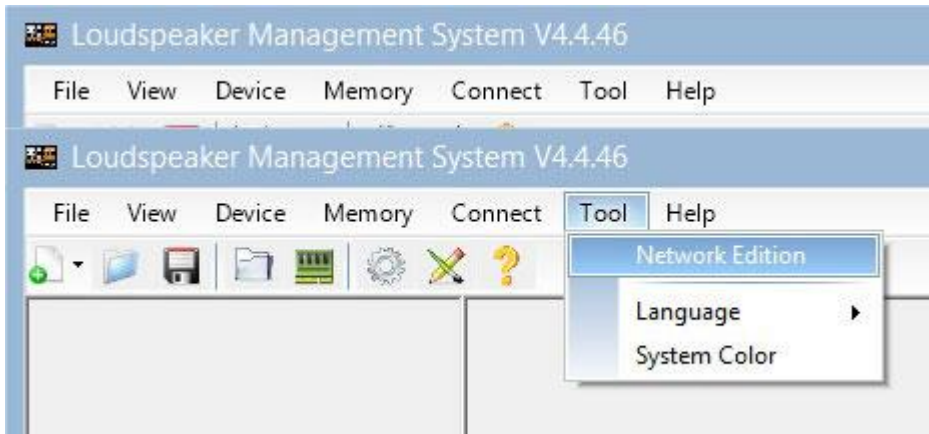

To create a system group, click “Tool” > “Network Edition”

Then click on the **magnifying glass** icon;



The following dialog box will appear. Click “OK” button”.



Once the previous step has been completed, all the units connected to the network will be displayed on the left of the menu (the group has not been created yet). Then click “**Device List**” button”.

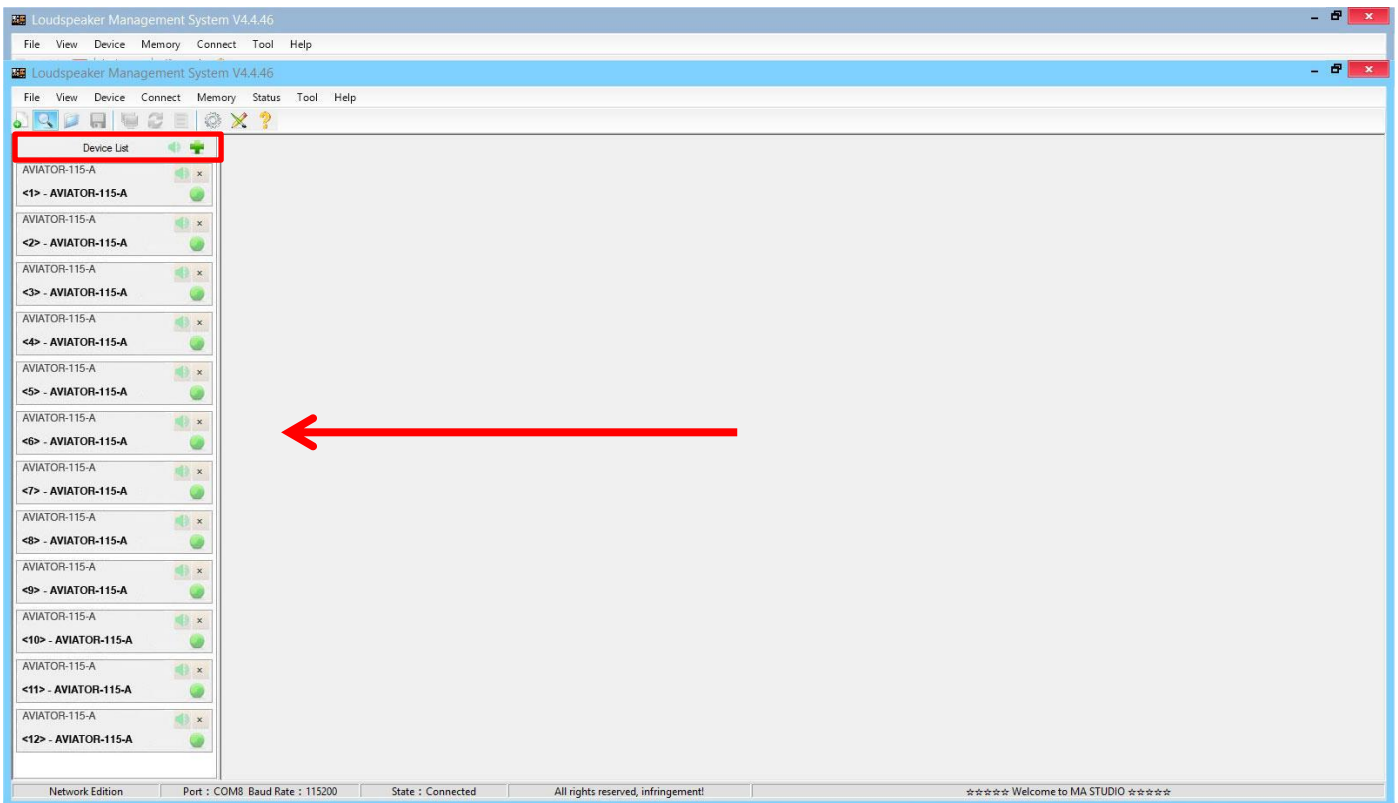

The following dialog box will appear;

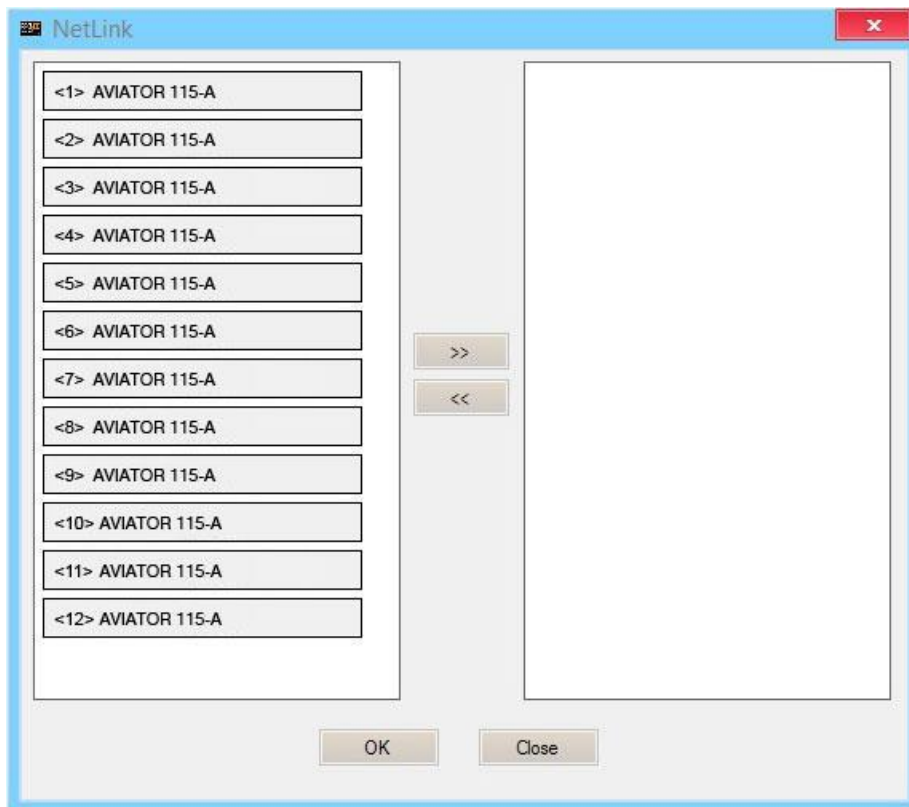

Next, we will select all the units that will be part of the group and click on the right arrow icon, the units that are displayed in the box on the right are the ones that will be part of the same group;

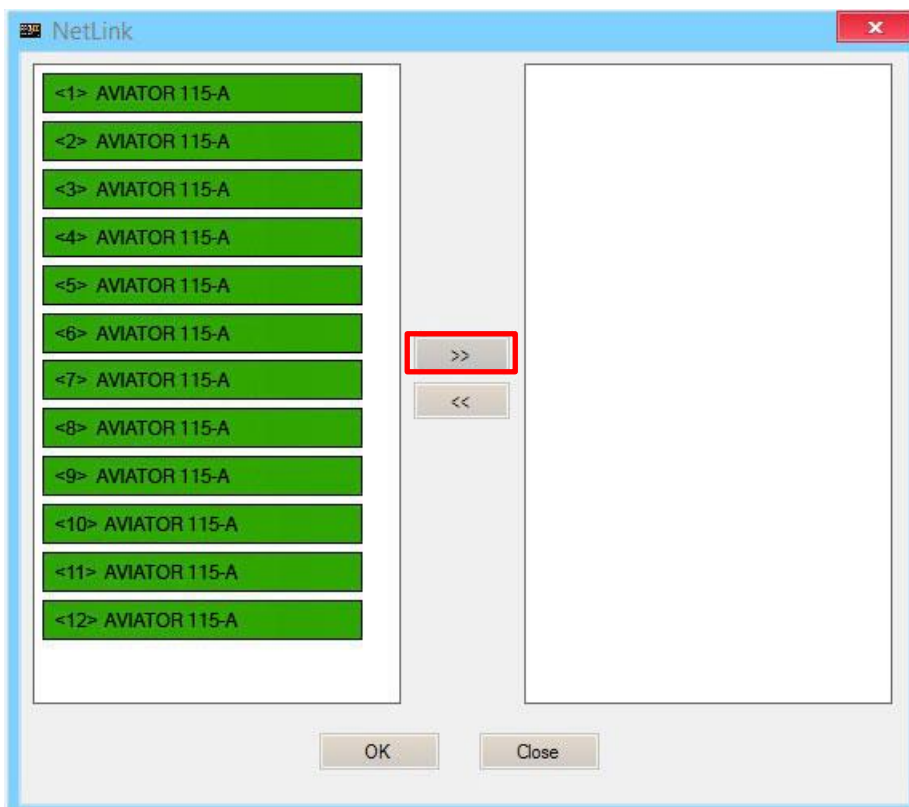

We will press “**OK**” button, which will cause the following dialog box to appear, in which we can modify the name of the created group, as well as different parameters of it;

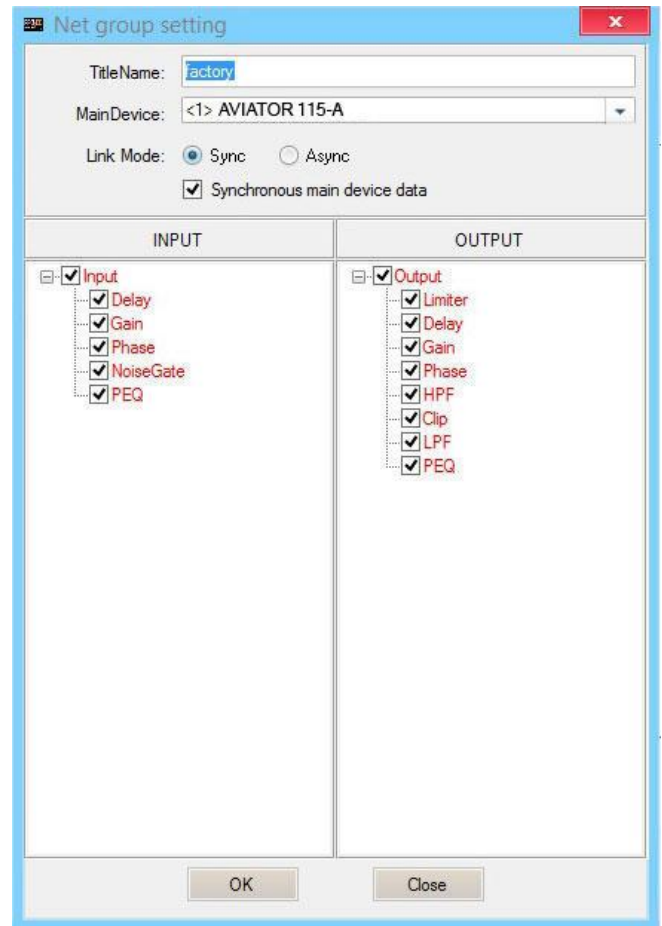

By pressing “**OK**” button in the previous step, the group creation process will be completed. In the menu on the left we can see that all the selected units are already part of the same group.

DSP. Selecting presets in the unit itself

It is possible to select stored presets in the DSP unit, directly from the AVIATOR 115 A amplifier. To do this, follow the following steps:

1. Connect the system to the mains and put the switch button in ON position.



2. Move the preset selector to select the desired preset.

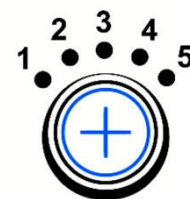

PRESETS	
1	MUSIC
2	VOCAL
3	DJ
4	AVIATOR S-115A
5	AVIATOR S-118A

The factory presets included are the following:

- Preset n°1: MUSIC; ideal for playing live music.
- Preset n°2: VOCAL; specific for voice.
- Preset n°3: DJ; ideal for playing recorded music.
- Preset n°4: to combine AVIATOR 115 A with AVIATOR S 115 A.
- Preset n°5: to combine AVIATOR 115 A with AVIATOR S 118 A.



If you have any technical problem or questions about Pro DG Systems products; contact our technical support department at: sat@prodgsystems.com

Usage in combo format with subwoofer

AVIATOR 115 A features a stand socket to attach an extendable bar, allowing it to work together with a subwoofer unit in combo format.

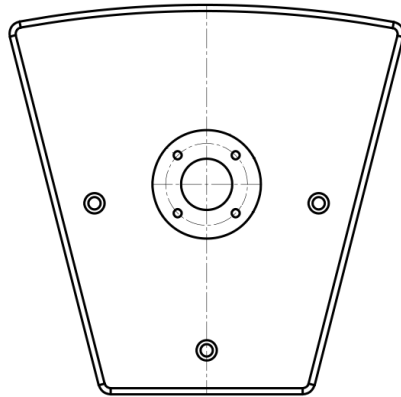

Extendable bar is not included, possibility of being supplied by Pro DG Systems as optional equipment.

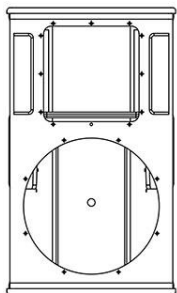

AVIATOR 115 A

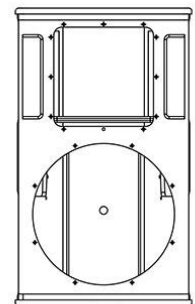

AVIATOR 115 A

Examples of use in combo format between AVIATOR 115 A and subwoofer AVIATOR S 115 A, or AVIATOR S 118 A.

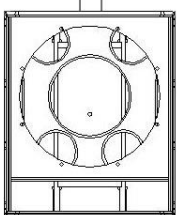

AVIATOR S 115 A

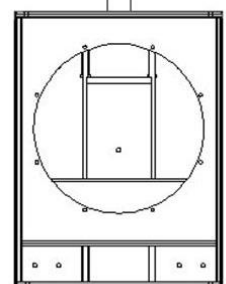

AVIATOR S 118 A

Hardware. Rigging points

AVIATOR 115 A has 12 M10 rigging points for fixing bolts, allowing a wide variety of installation possibilities on wall or ceiling.

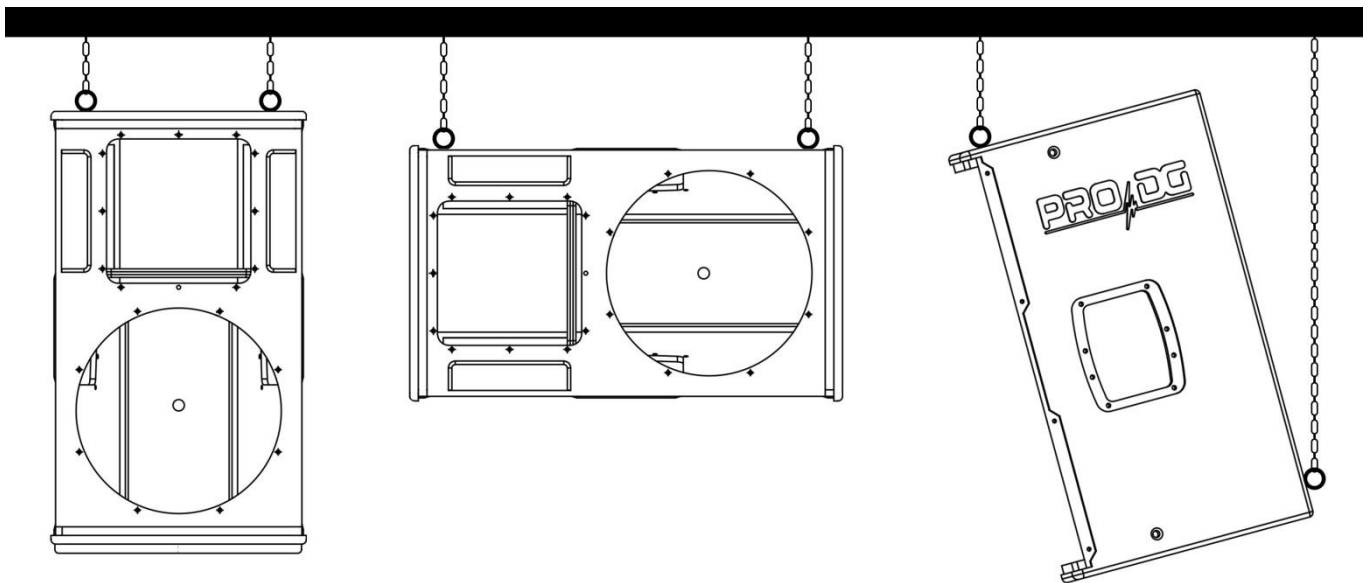
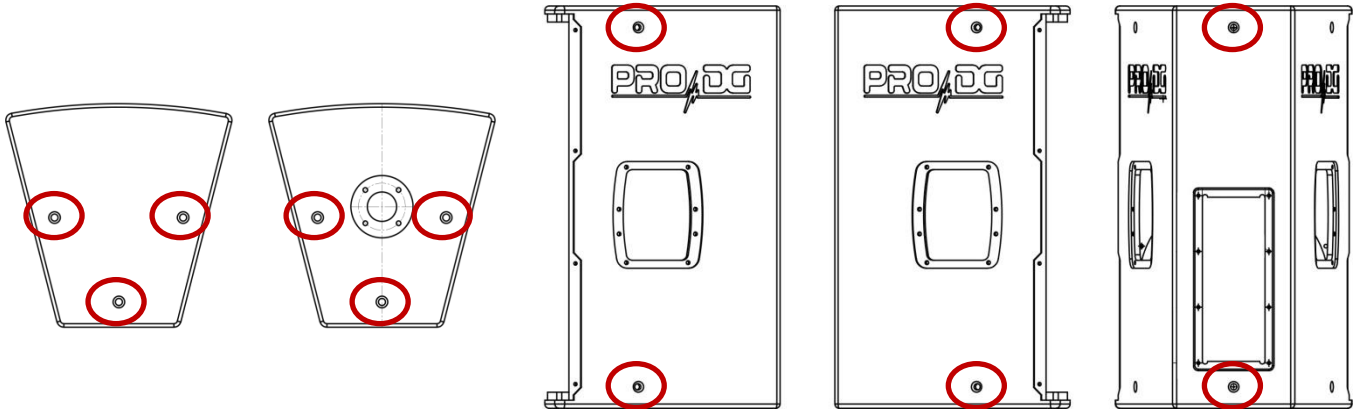

Safety instructions in case of flying the system



Before flying the system, it is mandatory to take into account the following safety instructions:

- Always carry out a visual and functional inspection of the various components before use. In case of doubt about the correct functioning and safety of the components, they must be removed from use immediately.
- The fly bar for AVIATOR 115 A (reference: FB 115), is designed to support up to a maximum of nine units AVIATOR 115 A, in cluster format (3 + 3 + 3). In no case should the aforementioned number of units be exceeded.
- The hanging of the units must be carried out by professionals with adequate knowledge of the components and hardware to be used. This process must be carried out by at least two people.
- It is the responsibility of the person or team installing the system to ensure that the suspension / fixing points are suitable for the intended use.
- The application of safety factors of 5:1 for enclosures and static parts is accepted in a standardized manner. For those elements subjected to fatigue due to friction and variations in the stresses to which they are subjected, the following safety factors must be met: 5:1 for steel cable slings, 4:1 for steel chain slings and 7:1 for polyester slings. This means that an element with a breaking stress of 1000 Kg can be subjected to a static working load of 200 Kg (safety factor 5:1) and a dynamic load of only 142 Kg (safety factor 7:1).
- When hanging a system, the working load must be less than the strength of each individual anchor point as well as each enclosure.
- When suspending elements from the ceiling or other structures, extreme caution must be taken by previously calculating their resistance. Sound systems should never be hung on structures that do not guarantee full safety guarantees.
- When hoists are in operation (when lifting the system), ensure that no one is directly under or near the load.
- It will be necessary to fix at different points those systems that are subject to gusts of wind, to avoid their swaying. In no case is it recommended to fly systems that are subject to strong gusts of wind.

- No risk should be accepted in terms of public safety. It is the responsibility of the person or team of people carrying out the assembly to provide themselves with personal safety elements, such as helmet, gloves, safety footwear, etc., to carry out this work. As well as the correct signage of the space in which work is being done.
- All accessories used to fly a Pro DG Systems sound system not provided by Pro DG Systems are the responsibility of the user(s).

In no case will Pro DG Systems be responsible for damages caused by incorrect use of the flying system by the user or users, whether physical damage to people or damage to the product or the attached facilities. As well as for failure to comply with the previously indicated safety instructions.

Flight hardware components

At Pro DG Systems we know the importance for the professional of installing the different systems in a simple, fast and safe way. AVIATOR 115 A flight system has been designed to guarantee these purposes. The different components are detailed below:

FB 115

Made of high-strength steel with oven-dried black electrostatic powder paint finish.

It allows the raise up of a maximum of nine units AVIATOR 115 A (3 + 3 + 3), in cluster format.

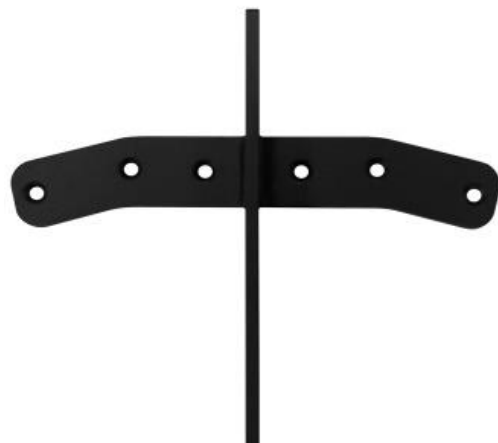

Lower hardware link

They allow the lower part of the AVIATOR 115 A units to be fixed in order to be used in cluster format.

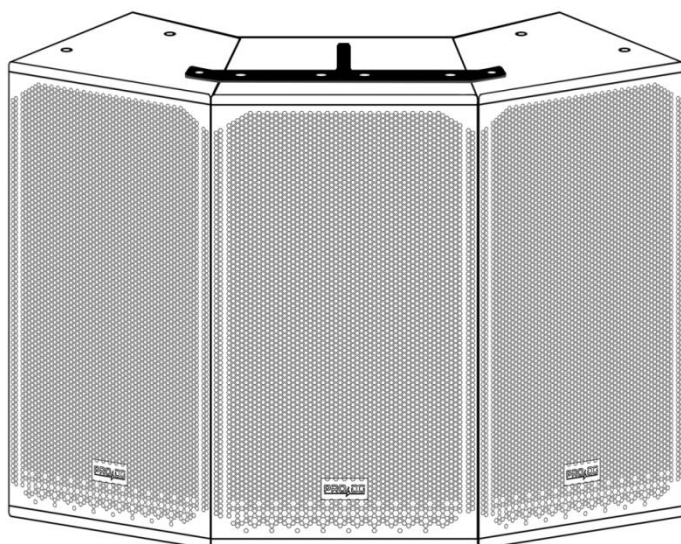
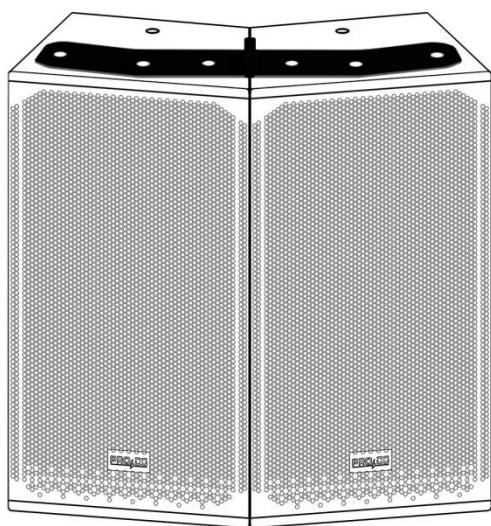

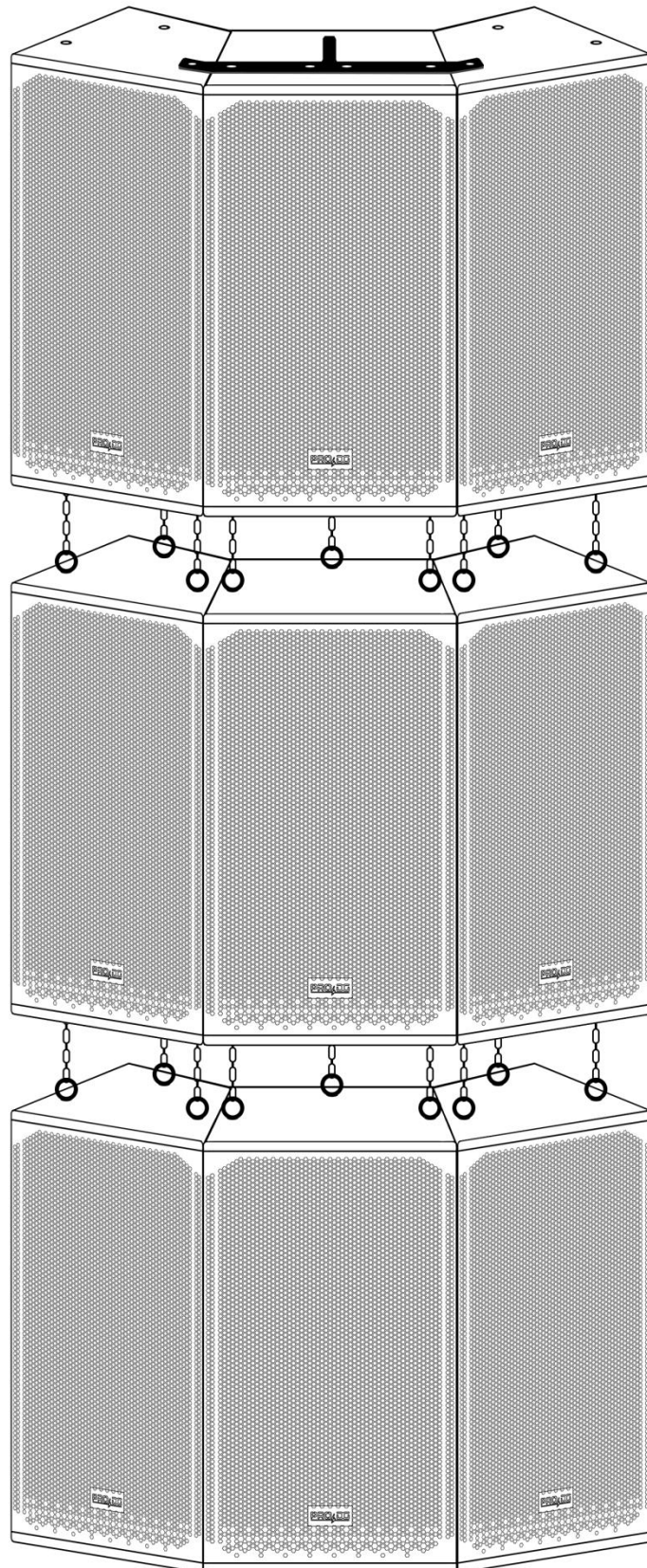

Note: the specifications of these components may be changed without prior notice. To be aware of the latest modifications, please consult Pro DG Systems website periodically.

How to fly the system up

Important: before flying the system, carefully read the subsection “Safety instructions”, located in the “Flight hardware” section (pages 33 - 34).

In case of using two units in cluster format:

1 Remove the screws located at the top and bottom, indicated below:

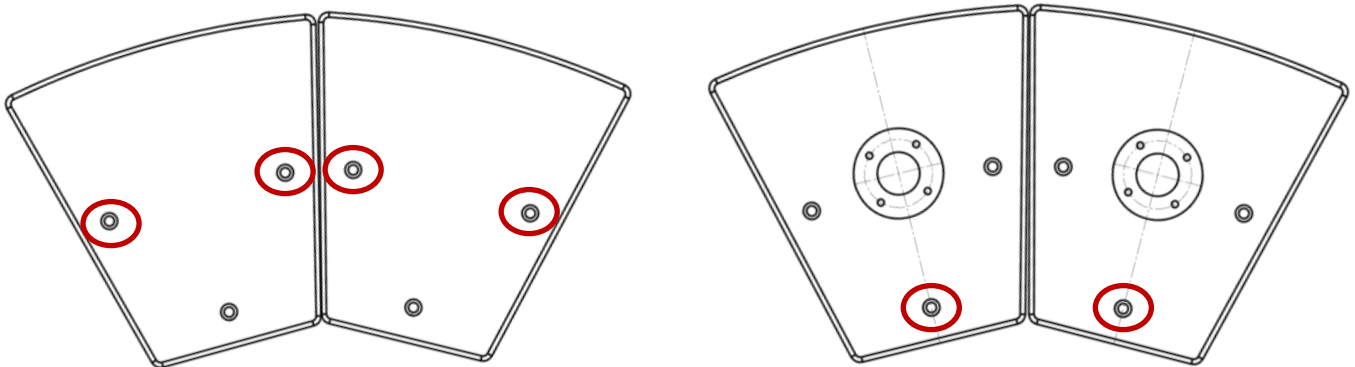

2 Screw the lower hardware link and the FB 115 fly bar into the indicated points:

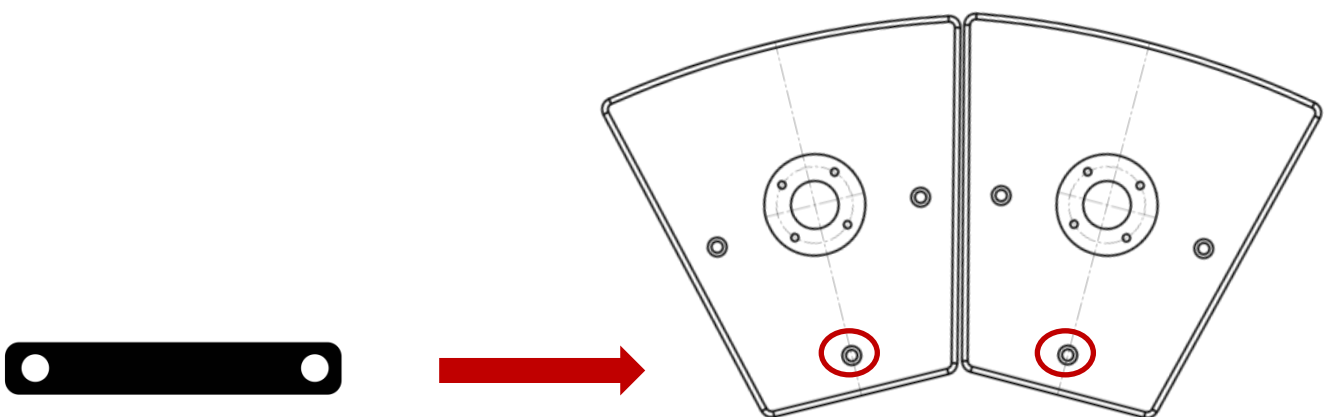

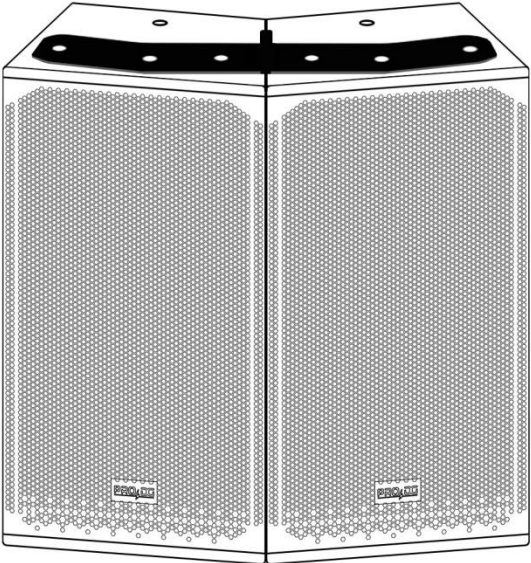
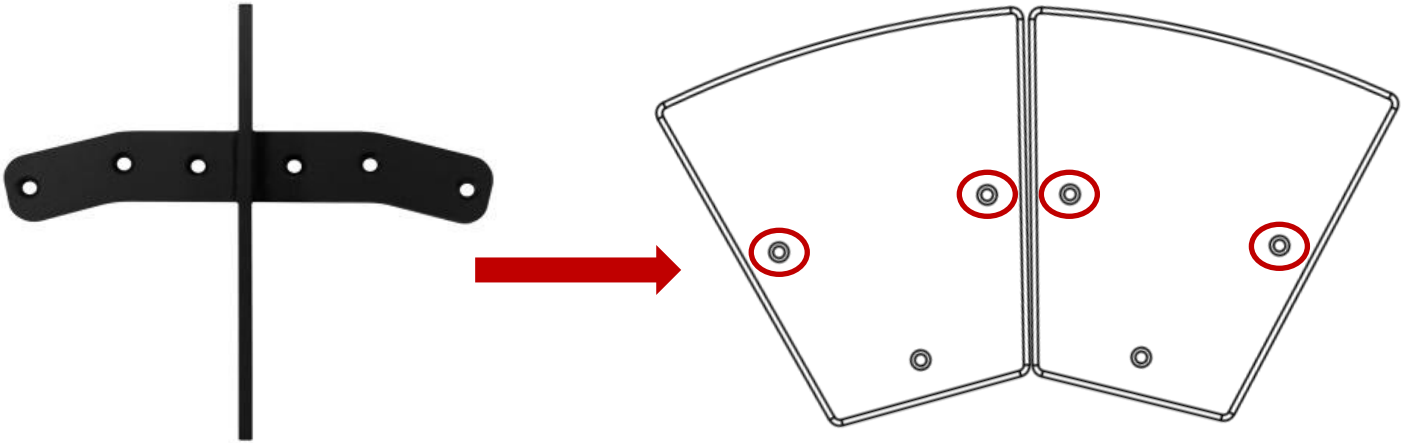

3 Install the shackle to the fly bar to raise the assembly. The fly bar has different accommodations to provide angulation to the assembly, depending on where the shackle is fixed to the fly bar.

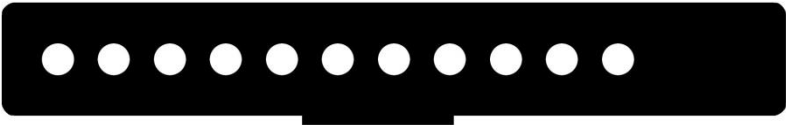

In case of using three units in cluster format:

You will only have to remove the screws indicated at the top:

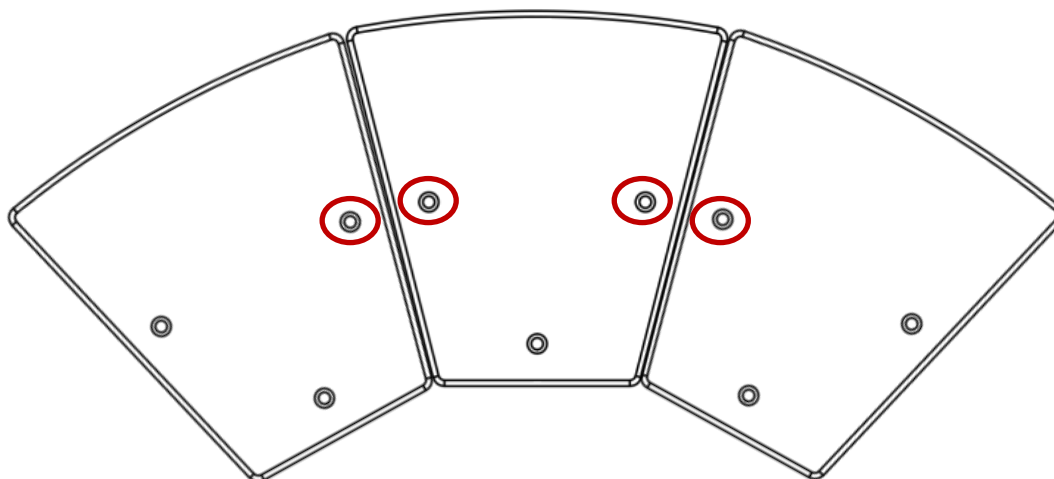

The rest of the steps to follow are the same as those described above, when using two units in cluster format.

You can fly up to nine units in cluster format (3 + 3 + 3), by fixing bolts at the rigging points (M10) and using chains or slings.

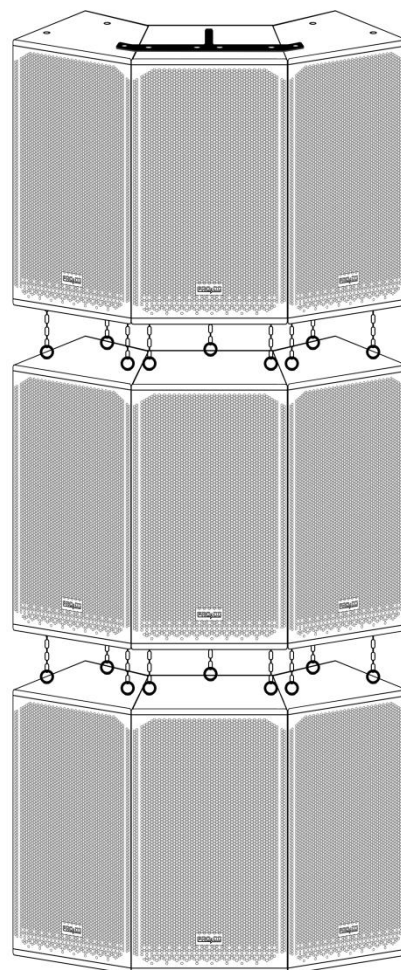

Ease Focus prediction software

At Pro DG Systems we know that manufacturing high-quality speakers is an important part of the job. The guarantee of being able to use the systems properly is the other fundamental part of our work. Good tools make the difference to achieve optimal use of systems.

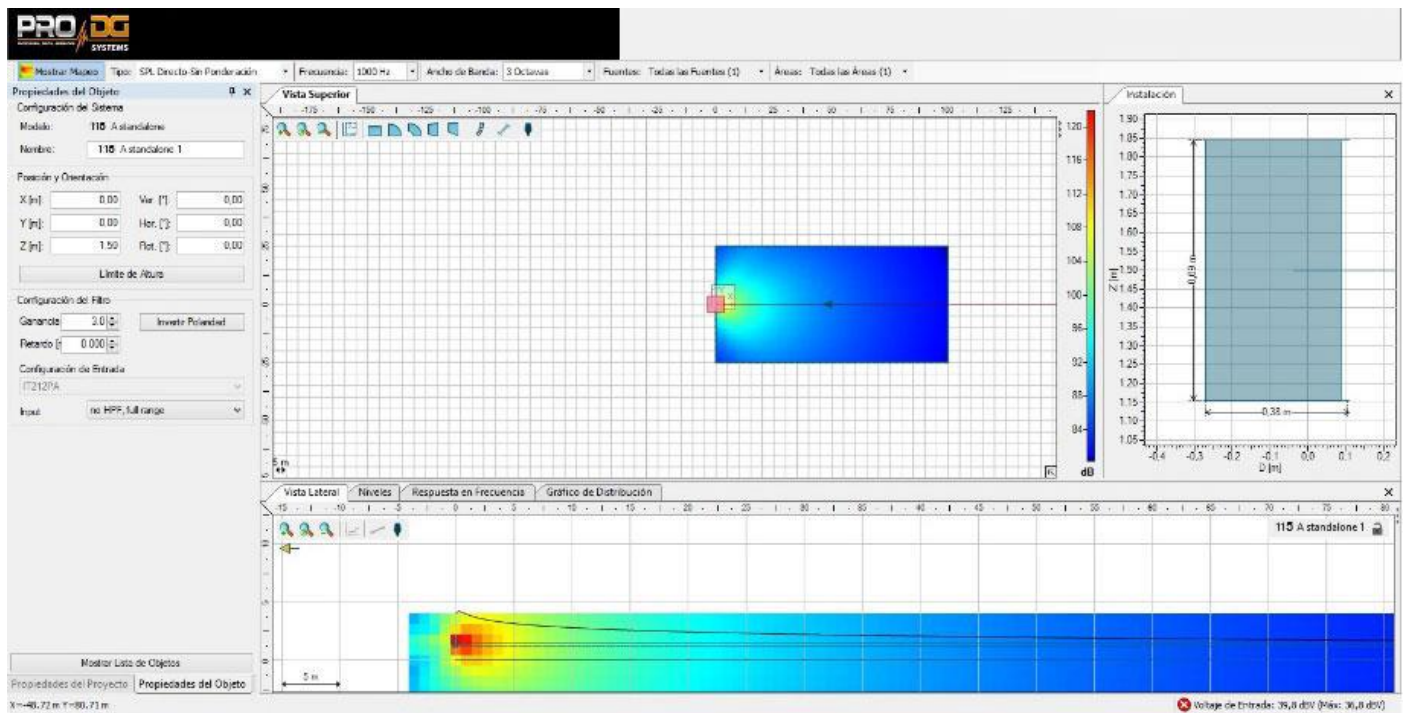

AVIATOR 115 A has Ease Focus V3 prediction software with which we can simulate the behavior of different systems in different places and circumstances, as well as obtain information on coverage, frequency, SPL and general behavior of the system, in a simple and comfortable way for the user. It is very easy to use and we have training courses for users of Pro DG Systems products. For more information, consult our technical service at: sat@prodgsystems.com

Ease Focus prediction software can be downloaded directly at Pro DG Systems website: <https://prodgsystems.com/19-scrpt-software.html>

You can download the user guide of Ease Focus 3 software [here](#)

You will find GLL files to simulate the behavior of AVIATOR 115 A at: www.prodgsystems.com

Accessories

Complete system wiring ready to work.





AVIATOR 115 A

PRO DG SYSTEMS INTERNATIONAL

P.I. Santa Bárbara. C/ Aceituneros nº 5.
41580 Casariche (Sevilla), Spain
Tel: +34 954 011 095
Cel: +34 678 548 947
export@prodgsystems.com
info@prodgsystems.com
www.prodgsystems.com

PRO DG SYSTEMS AMERICA

1225 NW 93rd CT
Doral, FL, 33172
Español: (786)-715-4705
English: (786) 314-1856
sales@prodgamerica.com
www.prodgamerica.com